

EVLYS LTD. - POWER SEMICONDUCTORS DEVICES - Wholesale and Retail.

Avalanche Stud Thyristor Type STA32-320-12

Optimum power handling / Low on-state and switching losses
Designed for traction and industrial applications

Mean on-state current	I_{TAV}		320 A				
Repetitive peak off-state voltage	V_{DRM}		600÷1200 V				
Repetitive peak reverse voltage	V_{RRM}						
Turn-off time	t_q		160 μ s				
V_{DRM}, V_{RRM}, V	600	700	800	900	1000	1100	1200
Voltage code	6	7	8	9	10	11	12
$T_j, ^\circ C$	-60÷140						

MAXIMUM ALLOWABLE RATINGS

Symbols and parameters		Units	Values	Test conditions	
ON-STATE					
I_{TAV}	Mean on-state current	A	320	$T_c = 97^\circ C$; 180° half-sine wave; 50 Hz	
I_{TRMS}	RMS on-state current	A	502	$T_c = 97^\circ C$; 180° half-sine wave; 50 Hz	
I_{TSM}	Surge on-state current	kA	9.0 10.5	$T_j = T_{jmax}$ $T_j = 25^\circ C$	180° half-sine wave; $t_p = 10$ ms; single pulse; $V_D = V_R = 0$ V; Gate pulse: $I_G = 2$ A; $t_{GP} = 50$ μ s; $di_G/dt \geq 1$ A/ μ s
			9.5 11.0	$T_j = T_{jmax}$ $T_j = 25^\circ C$	180° half-sine wave; $t_p = 8.3$ ms; single pulse; $V_D = V_R = 0$ V; Gate pulse: $I_G = 2$ A; $t_{GP} = 50$ μ s; $di_G/dt \geq 1$ A/ μ s
I^2t	Safety factor	$A^2s \cdot 10^3$	400 550	$T_j = T_{jmax}$ $T_j = 25^\circ C$	180° half-sine wave; $t_p = 10$ ms; single pulse; $V_D = V_R = 0$ V; Gate pulse: $I_G = 2$ A; $t_{GP} = 50$ μ s; $di_G/dt \geq 1$ A/ μ s
			370 500	$T_j = T_{jmax}$ $T_j = 25^\circ C$	180° half-sine wave; $t_p = 8.3$ ms; single pulse; $V_D = V_R = 0$ V; Gate pulse: $I_G = 2$ A; $t_{GP} = 50$ μ s; $di_G/dt \geq 1$ A/ μ s
BLOCKING					
V_{DRM}, V_{RRM}	Repetitive peak off-state and Repetitive peak reverse voltages	V	600÷1200	$T_{jmin} < T_j < T_{jmax}$; 180° half-sine wave; 50 Hz; Gate open	
V_{DSM}, V_{RSM}	Non-repetitive peak off-state and Non-repetitive peak reverse voltages	V	700÷1300	$T_{jmin} < T_j < T_{jmax}$; 180° half-sine wave; single pulse; Gate open	
$V_{(BR)}$	Breakdown voltage	V	850÷1700	$T_{jmin} < T_j < T_{jmax}$; $I_{RRM} = 100$ mA; 180° half-sine wave; single pulse; Gate open	

EVLYS LTD. - POWER SEMICONDUCTORS DEVICES - Wholesale and Retail.

V_{D}, V_R	Direct off-state and Direct reverse voltages	V	$0.6 \cdot V_{DRM}$ $0.6 \cdot V_{RRM}$	$T_j = T_{j \max}$; Gate open
P_{RSM}	Surge reverse power dissipation	kW	16	$T_j = T_{j \max}$; $t_p = 100 \mu s$; 180° half-sine wave; single pulse
TRIGGERING				
I_{FGM}	Peak forward gate current	A	6	$T_j = T_{j \max}$
V_{RGM}	Peak reverse gate voltage	V	5	
P_G	Gate power dissipation	W	3	$T_j = T_{j \max}$ for DC gate current
SWITCHING				
$(di_T/dt)_{crit}$	Critical rate of rise of on-state current non-repetitive ($f=1$ Hz)	A/ μs	800	$T_j = T_{j \max}$; $V_D = 0.67 \cdot V_{DRM}$; $I_{TM} = 3000$ A; Gate pulse: $I_G = 2$ A; $t_{GP} = 50 \mu s$; $di_G/dt \geq 2$ A/ μs
THERMAL				
T_{stg}	Storage temperature	$^\circ C$	-60÷50	
T_j	Operating junction temperature	$^\circ C$	-60÷140	
MECHANICAL				
M	Tightening torque	Nm	25÷35	
a	Acceleration	m/s ²	100	

CHARACTERISTICS

Symbols and parameters		Units	Values	Conditions	
ON-STATE					
V_{TM}	Peak on-state voltage, max	V	1.65	$T_j = 25^\circ C$; $I_{TM} = 1005$ A	
$V_{T(TO)}$	On-state threshold voltage, max	V	1.012	$T_j = T_{j \max}$;	
r_T	On-state slope resistance, max	m Ω	0.717	$0.5 \pi I_{TAV} < I_T < 1.5 \pi I_{TAV}$	
I_L	Latching current, max	mA	700	$T_j = 25^\circ C$; $V_D = 12$ V; Gate pulse: $I_G = 2$ A; $t_{GP} = 50 \mu s$; $di_G/dt \geq 1$ A/ μs	
I_H	Holding current, max	mA	300	$T_j = 25^\circ C$; $V_D = 12$ V; Gate open	
BLOCKING					
I_{DRM}, I_{RRM}	Repetitive peak off-state and Repetitive peak reverse currents, max	mA	35	$T_j = T_{j \max}$; $V_D = V_{DRM}$; $V_R = V_{RRM}$	
$(dv_D/dt)_{crit}$	Critical rate of rise of off-state voltage ¹⁾ , min	V/ μs	320 500 1000	$T_j = T_{j \max}$; $V_D = 0.67 \cdot V_{DRM}$; Gate open	
TRIGGERING					
V_{GT}	Gate trigger direct voltage, max	V	3.00 2.50 1.50	$T_j = T_{j \min}$ $T_j = 25^\circ C$ $T_j = T_{j \max}$	$V_D = 12$ V; $I_D = 3$ A; Direct gate current
I_{GT}	Gate trigger direct current, max	mA	400 250 150	$T_j = T_{j \min}$ $T_j = 25^\circ C$ $T_j = T_{j \max}$	
V_{GD}	Gate non-trigger direct voltage, min	V	0.60	$T_j = T_{j \max}$;	
I_{GD}	Gate non-trigger direct current, min	mA	30.00	$V_D = 0.67 \cdot V_{DRM}$; Direct gate current	
SWITCHING					
t_{gd}	Delay time, max	μs	1.25	$T_j = 25^\circ C$; $V_D = 600$ V; $I_{TM} = I_{TAV}$; $di/dt = 200$ A/ μs ;	
t_{gt}	Turn-on time, max	μs	4.00	Gate pulse: $I_G = 2$ A; $V_G = 20$ V; $t_{GP} = 50 \mu s$; $di_G/dt = 2$ A/ μs	
t_q	Turn-off time ²⁾ , max	μs	160	$dv_D/dt = 50$ V/ μs ; $T_j = T_{j \max}$; $I_{TM} = I_{TAV}$; $di_R/dt = -10$ A/ μs ; $V_R = 100$ V; $V_D = 0.67 \cdot V_{DRM}$;	
Q_{rr}	Total recovered charge, max	μC	490	$T_j = T_{j \max}$; $I_{TM} = 320$ A;	
t_{rr}	Reverse recovery time, max	μs	13.0		

EVLYS LTD. - POWER SEMICONDUCTORS DEVICES - Wholesale and Retail.

I_{rrM}	Peak reverse recovery current, max	A	75.0	$di_R/dt = -10 \text{ A}/\mu\text{s};$ $V_R = 100 \text{ V}$
-----------	------------------------------------	---	------	---

THERMAL

R_{thjc}	Thermal resistance, junction to case, max	$^{\circ}\text{C}/\text{W}$	0.0850	Direct current
------------	---	-----------------------------	--------	----------------

MECHANICAL

w	Weight, max	g	440	
D_s	Surface creepage distance	mm (inch)	12.4 (4.882)	
D_a	Air strike distance	mm (inch)	12.4 (4.882)	

PART NUMBERING GUIDE

STA	32	320	12	7	3
1	2	3	4	5	6

1. STA - Avalanche Stud Thyristor
2. Element Diameter
3. Mean on-state current, A
4. Voltage code
5. Critical rate of rise of on-state current non-repetitive, $\text{V}/\mu\text{s}$
6. Turn-off time ($dv_D/dt = 50 \text{ V}/\mu\text{s}$)

NOTES

- 1) Critical rate of rise of on-state current non-repetitive

Symbol of Group	5	6	7
$(dv_D/dt)_{critr} \text{ V}/\mu\text{s}$	320	500	1000

- 2) Turn-off time ($dv_D/dt = 50 \text{ V}/\mu\text{s}$)

Symbol of Group	3
$t_{qr} \mu\text{s}$	160

EVLYS LTD. - POWER SEMICONDUCTORS DEVICES - Wholesale and Retail.

OVERALL DIMENSIONS

Package type: **T.SB1**

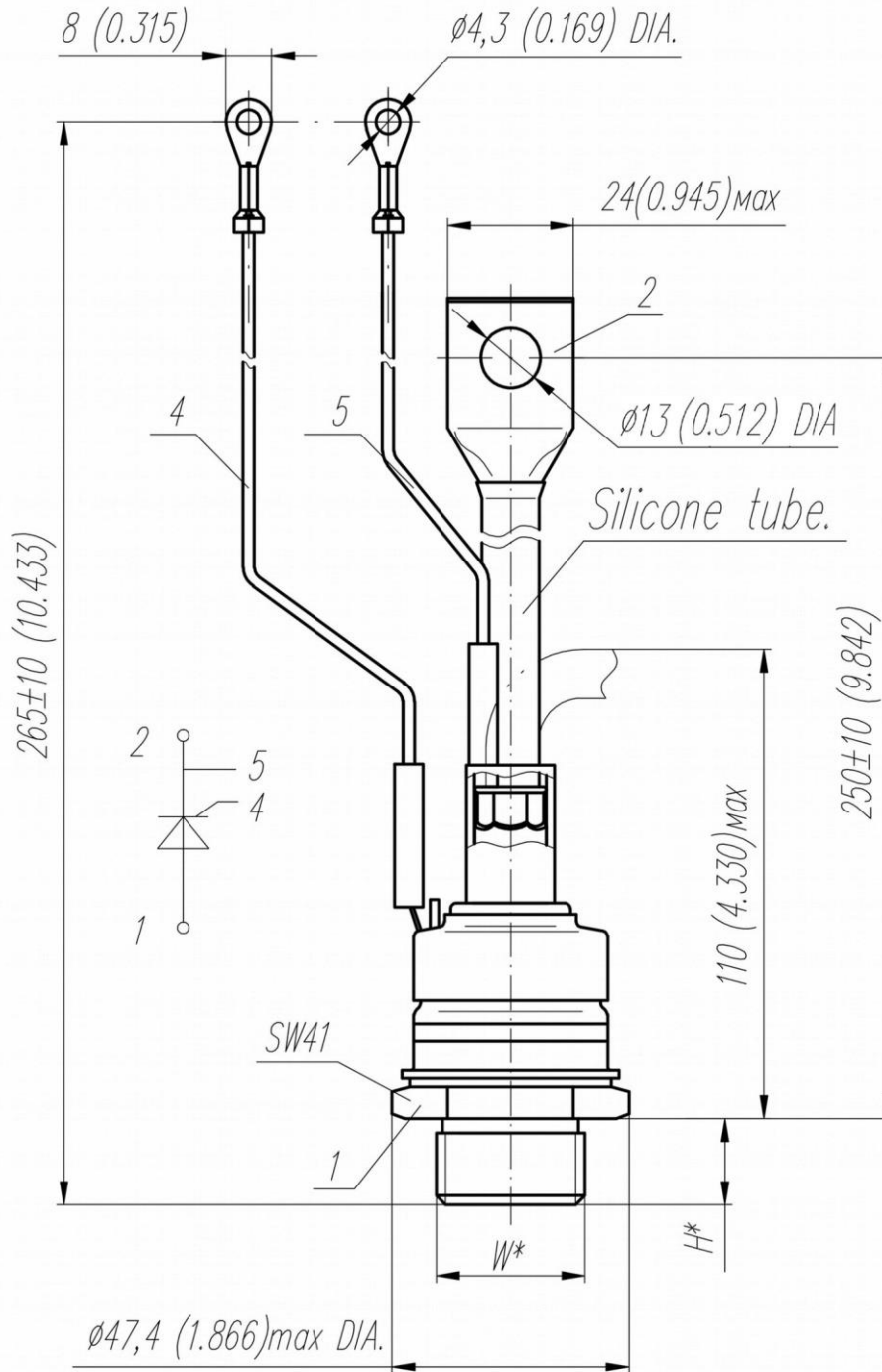

Type of screw	W	H
Metric Screw Type C	M24x1,5 – 8g	19
Metric Screw Type B (upon request)	M20x1,5 – 8g	15

Polarity	Example of code designation	Reference designation	Colors		
			Anode	Cathode	Gate
Anode to stud	STA32_27		-	Red tube	White

All dimensions in millimeters (inches)