

EVLYS LTD. - POWER SEMICONDUCTORS DEVICES - Wholesale and Retail.

Fast Inverter Stud Thyristor Type **FST32-160-14**

Pressure contact / Low switching losses / Low reverse recovery charge
High power cycling capability / Distributed amplified gate for high di_T/dt

Mean on-state current	I_{TAV}		160 A		
Repetitive peak off-state voltage	V_{DRM}		1000...1400 V		
Repetitive peak reverse voltage	V_{RRM}				
Turn-off time	t_q		16.0, 20.0, 25.0, 32.0 μs		
V_{DRM}, V_{RRM}, V	1000	1100	1200	1300	1400
Voltage code	10	11	12	13	14
$T_j, ^\circ C$	-60...+125				

MAXIMUM ALLOWABLE RATINGS

Symbols and parameters		Units	Values	Test conditions
ON-STATE				
I_{TAV}	Maximum allowable mean on-state current	A	160 220 327	$T_c=98^\circ C$; $T_c=85^\circ C$; $T_c=55^\circ C$; 180° half-sine wave; 50 Hz
I_{TRMS}	RMS on-state current	A	251	$T_c=98^\circ C$; 180° half-sine wave; 50 Hz
I_{TSM}	Surge on-state current	kA	6.0 7.0	$T_j=T_{jmax}$ $T_j=25^\circ C$ 180° half-sine wave; $t_p=10$ ms; single pulse; $V_D=V_R=0$ V; Gate pulse: $I_G=I_{FGM}$; $V_G=20$ V; $t_{GP}=50$ μs ; $di_G/dt=1$ A/ μs
			6.5 7.5	$T_j=T_{jmax}$ $T_j=25^\circ C$ 180° half-sine wave; $t_p=8.3$ ms; single pulse; $V_D=V_R=0$ V; Gate pulse: $I_G=I_{FGM}$; $V_G=20$ V; $t_{GP}=50$ μs ; $di_G/dt=1$ A/ μs
I^2t	Safety factor	$A^2s \cdot 10^3$	180 240	$T_j=T_{jmax}$ $T_j=25^\circ C$ 180° half-sine wave; $t_p=10$ ms; single pulse; $V_D=V_R=0$ V; Gate pulse: $I_G=I_{FGM}$; $V_G=20$ V; $t_{GP}=50$ μs ; $di_G/dt=1$ A/ μs
			170 230	$T_j=T_{jmax}$ $T_j=25^\circ C$ 180° half-sine wave; $t_p=8.3$ ms; single pulse; $V_D=V_R=0$ V; Gate pulse: $I_G=I_{FGM}$; $V_G=20$ V; $t_{GP}=50$ μs ; $di_G/dt=1$ A/ μs
BLOCKING				
V_{DRM}, V_{RRM}	Repetitive peak off-state and Repetitive peak reverse voltages	V	1000...1400	$T_{jmin} < T_j < T_{jmax}$; 180° half-sine wave; 50 Hz; Gate open
V_{DSM}, V_{RSM}	Non-repetitive peak off-state and Non-repetitive peak reverse voltages	V	1100...1500	$T_{jmin} < T_j < T_{jmax}$; 180° half-sine wave; single pulse; Gate open
V_D, V_R	Direct off-state and Direct reverse voltages	V	$0.6 \cdot V_{DRM}$ $0.6 \cdot V_{RRM}$	$T_j=T_{jmax}$; Gate open

EVLYS LTD. - POWER SEMICONDUCTORS DEVICES - Wholesale and Retail.

TRIGGERING				
I_{FGM}	Peak forward gate current	A	6	$T_j = T_{j\max}$
V_{RGM}	Peak reverse gate voltage	V	5	
P_G	Gate power dissipation	W	3	$T_j = T_{j\max}$ for DC gate current
SWITCHING				
$(di_T/dt)_{crit}$	Critical rate of rise of on-state current non-repetitive (f=1 Hz)	A/ μ s	1600	$T_j = T_{j\max}$; $V_D = 0.67 \cdot V_{DRM}$; $I_{TM} = 320$ A; Gate pulse: $I_G = 2$ A; $V_G = 20$ V; $t_{GP} = 50$ μ s; $di_G/dt = 2$ A/ μ s
THERMAL				
T_{stg}	Storage temperature	$^{\circ}$ C	-60...+50	
T_j	Operating junction temperature	$^{\circ}$ C	-60...+125	
MECHANICAL				
M	Tightening torque	Nm	25...35	
a	Acceleration	m/s ²	100	

CHARACTERISTICS

Symbols and parameters		Units	Values	Conditions	
ON-STATE					
V_{TM}	Peak on-state voltage, max	V	2.20	$T_j = 25$ $^{\circ}$ C; $I_{TM} = 502$ A	
$V_{T(TO)}$	On-state threshold voltage, max	V	1.366	$T_j = T_{j\max}$;	
r_T	On-state slope resistance, max	m Ω	1.430	$0.5 \pi I_{TAV} < I_T < 1.5 \pi I_{TAV}$	
I_H	Holding current, max	mA	500	$T_j = 25$ $^{\circ}$ C; $V_D = 12$ V; Gate open	
BLOCKING					
I_{DRM}, I_{RRM}	Repetitive peak off-state and Repetitive peak reverse currents, max	mA	70	$T_j = T_{j\max}$; $V_D = V_{DRM}$; $V_R = V_{RRM}$	
$(dv_D/dt)_{crit}$	Critical rate of rise of off-state voltage ¹⁾ , min	V/ μ s	200, 320, 500, 1000, 1600, 2000, 2500	$T_j = T_{j\max}$; $V_D = 0.67 \cdot V_{DRM}$; Gate open	
TRIGGERING					
V_{GT}	Gate trigger direct voltage, max	V	3.00 2.50 1.50	$T_j = T_{j\min}$ $T_j = 25$ $^{\circ}$ C $T_j = T_{j\max}$	$V_D = 12$ V; $I_D = 3$ A; Direct gate current
I_{GT}	Gate trigger direct current, max	mA	400 250 150	$T_j = T_{j\min}$ $T_j = 25$ $^{\circ}$ C $T_j = T_{j\max}$	
V_{GD}	Gate non-trigger direct voltage, min	V	0.40	$T_j = T_{j\max}$;	
I_{GD}	Gate non-trigger direct current, min	mA	50.00	$V_D = 0.67 \cdot V_{DRM}$; Direct gate current	
SWITCHING					
t_{gd}	Delay time, max	μ s	0.80	$T_j = 25$ $^{\circ}$ C; $V_D = 600$ V; $I_{TM} = I_{TAV}$; $di/dt = 200$ A/ μ s;	
t_{gt}	Turn-on time ²⁾ , max	μ s	1.60, 2.00, 2.50, 3.20	Gate pulse: $I_G = 2$ A; $V_G = 20$ V; $t_{GP} = 50$ μ s; $di_G/dt = 2$ A/ μ s	
t_q	Turn-off time ³⁾ , max	μ s	16.0, 20.0, 25.0, 32.0	$dv_D/dt = 50$ V/ μ s; $T_j = T_{j\max}$; $I_{TM} = I_{TAV}$; $di_R/dt = -10$ A/ μ s; $V_R = 100$ V; $V_D = 0.67 V_{DRM}$	
Q_{rr}	Recovered charge, max	μ C	100	$T_j = T_{j\max}$; $I_{TM} = I_{TAV}$;	
t_{rr}	Reverse recovery time, max	μ s	3.2	$di_R/dt = -50$ A/ μ s;	
I_{rr}	Reverse recovery current, max	A	63	$V_R = 100$ V	

EVLYS LTD. - POWER SEMICONDUCTORS DEVICES - Wholesale and Retail.

THERMAL				
R_{thjc}	Thermal resistance, junction to case, max	$^{\circ}\text{C/W}$	0.085	Direct current
MECHANICAL				
m	Weight, max	g	440	
D_s	Surface creepage distance	mm (inch)	12.4 (4.882)	
D_a	Air strike distance	mm (inch)	12.4 (4.882)	

PART NUMBERING GUIDE							NOTES																																										
FST	32	160	14	7	5	4																																											
1	2	3	4	5	6	7																																											
1. FST — Fast Inverter Stud Thyristor 2. Design version 3. Mean on-state current, A 4. Voltage code 5. Critical rate of rise of off-state voltage 6. Group of turn-off time ($dv_D/dt=50\text{ V}/\mu\text{s}$) 7. Group of turn-on time							1) Critical rate of rise of off-state voltage <table border="1" style="width: 100%; border-collapse: collapse;"> <thead> <tr> <th style="background-color: #cccccc;">Symbol of Group</th> <th style="background-color: #cccccc;">4</th> <th style="background-color: #cccccc;">5</th> <th style="background-color: #cccccc;">6</th> <th style="background-color: #cccccc;">7</th> <th style="background-color: #cccccc;">8</th> <th style="background-color: #cccccc;">8,5</th> <th style="background-color: #cccccc;">9</th> </tr> </thead> <tbody> <tr> <td>$(dv_D/dt)_{crit}, \text{ V}/\mu\text{s}$</td> <td>200</td> <td>320</td> <td>500</td> <td>1000</td> <td>1600</td> <td>2000</td> <td>2500</td> </tr> </tbody> </table> 2) Turn-on time <table border="1" style="width: 100%; border-collapse: collapse;"> <thead> <tr> <th style="background-color: #cccccc;">Symbol of group</th> <th style="background-color: #cccccc;">6</th> <th style="background-color: #cccccc;">5</th> <th style="background-color: #cccccc;">4</th> <th style="background-color: #cccccc;">3</th> </tr> </thead> <tbody> <tr> <td>$t_{gt}, \mu\text{s}$</td> <td>1.60</td> <td>2.00</td> <td>2.50</td> <td>3.20</td> </tr> </tbody> </table> 3) Turn-off time ($dv_D/dt=50\text{ V}/\mu\text{s}$) <table border="1" style="width: 100%; border-collapse: collapse;"> <thead> <tr> <th style="background-color: #cccccc;">Symbol of group</th> <th style="background-color: #cccccc;">7</th> <th style="background-color: #cccccc;">6</th> <th style="background-color: #cccccc;">5</th> <th style="background-color: #cccccc;">4</th> </tr> </thead> <tbody> <tr> <td>$t_q, \mu\text{s}$</td> <td>16.0</td> <td>20.0</td> <td>25.0</td> <td>32.0</td> </tr> </tbody> </table>							Symbol of Group	4	5	6	7	8	8,5	9	$(dv_D/dt)_{crit}, \text{ V}/\mu\text{s}$	200	320	500	1000	1600	2000	2500	Symbol of group	6	5	4	3	$t_{gt}, \mu\text{s}$	1.60	2.00	2.50	3.20	Symbol of group	7	6	5	4	$t_q, \mu\text{s}$	16.0	20.0	25.0	32.0
Symbol of Group	4	5	6	7	8	8,5	9																																										
$(dv_D/dt)_{crit}, \text{ V}/\mu\text{s}$	200	320	500	1000	1600	2000	2500																																										
Symbol of group	6	5	4	3																																													
$t_{gt}, \mu\text{s}$	1.60	2.00	2.50	3.20																																													
Symbol of group	7	6	5	4																																													
$t_q, \mu\text{s}$	16.0	20.0	25.0	32.0																																													

EVLYS LTD. - POWER SEMICONDUCTORS DEVICES - Wholesale and Retail.

OVERALL DIMENSIONS

Package type: **T.SB2**

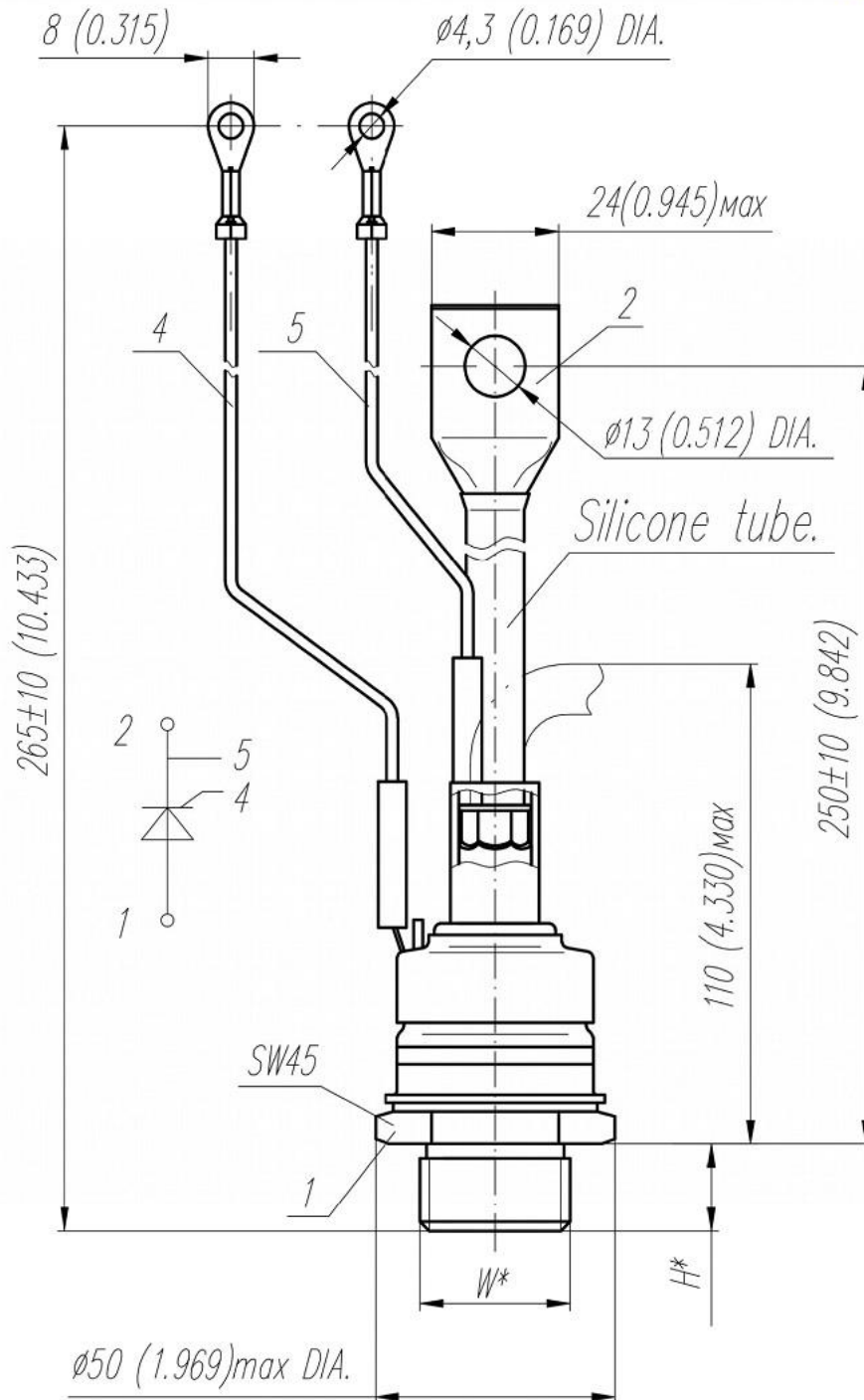

Type of screw	W	H
Metric Screw Type C	M24x1,5 – 8g	19
		15

Polarity	Example of code designation	Reference designation	Colors		
			Anode	Cathode	Gate
Anode to stud	FST32_37		-	Red tube	White

All dimensions in millimeters (inches)