

# EVLYS LTD. - POWER SEMICONDUCTORS DEVICES - Wholesale and Retail.

## Fast Inverter Thyristor Type FIDT32-400-12

Low switching losses / Low reverse recovery charge  
Distributed amplified gate for high  $di_T/dt$

Mean on-state current	$I_{TAV}$	400 A	
Repetitive peak off-state voltage	$V_{DRM}$	1000...1200 V	
Repetitive peak reverse voltage	$V_{RRM}$		
Turn-off time	$t_q$	5.00, 6.30, 8.00, 10.0 $\mu s$	
$V_{DRM}, V_{RRM}, V$	1000	1100	1200
Voltage code	10	11	12
$T_j, ^\circ C$	-60...+125		

### MAXIMUM ALLOWABLE RATINGS

Symbols and parameters		Units	Values	Test conditions
<b>ON-STATE</b>				
$I_{TAV}$	Mean on-state current	A	358 400 533	$T_c = 85^\circ C$ ; Double side cooled; $T_c = 78^\circ C$ ; Double side cooled; $T_c = 55^\circ C$ ; Double side cooled; 180° half-sine wave; 50 Hz
$I_{TRMS}$	RMS on-state current	A	628	$T_c = 78^\circ C$ ; Double side cooled; 180° half-sine wave; 50 Hz
$I_{TSM}$	Surge on-state current	kA	5.5 6.5	$T_j = T_{jmax}$ $T_j = 25^\circ C$ 180° half-sine wave; $t_p = 10$ ms; single pulse; $V_D = V_R = 0$ V; Gate pulse: $I_G = I_{FGM}$ ; $V_G = 20$ V; $t_{GP} = 50$ $\mu s$ ; $di_G/dt = 1$ A/ $\mu s$
			6.0 7.0	$T_j = T_{jmax}$ $T_j = 25^\circ C$ 180° half-sine wave; $t_p = 8.3$ ms; single pulse; $V_D = V_R = 0$ V; Gate pulse: $I_G = I_{FGM}$ ; $V_G = 20$ V; $t_{GP} = 50$ $\mu s$ ; $di_G/dt = 1$ A/ $\mu s$
$I^2t$	Safety factor	$A^2s \cdot 10^3$	150 210	$T_j = T_{jmax}$ $T_j = 25^\circ C$ 180° half-sine wave; $t_p = 10$ ms; single pulse; $V_D = V_R = 0$ V; Gate pulse: $I_G = I_{FGM}$ ; $V_G = 20$ V; $t_{GP} = 50$ $\mu s$ ; $di_G/dt = 1$ A/ $\mu s$
			140 200	$T_j = T_{jmax}$ $T_j = 25^\circ C$ 180° half-sine wave; $t_p = 8.3$ ms; single pulse; $V_D = V_R = 0$ V; Gate pulse: $I_G = I_{FGM}$ ; $V_G = 20$ V; $t_{GP} = 50$ $\mu s$ ; $di_G/dt = 1$ A/ $\mu s$
<b>BLOCKING</b>				
$V_{DRM}, V_{RRM}$	Repetitive peak off-state and Repetitive peak reverse voltages	V	1000...1200	$T_{jmin} < T_j < T_{jmax}$ ; 180° half-sine wave; 50 Hz; Gate open
$V_{DSM}, V_{RSM}$	Non-repetitive peak off-state and Non-repetitive peak reverse voltages	V	1100...1300	$T_{jmin} < T_j < T_{jmax}$ ; 180° half-sine wave; single pulse; Gate open
$V_D, V_R$	Direct off-state and Direct reverse voltages	V	$0.6 \cdot V_{DRM}$ $0.6 \cdot V_{RRM}$	$T_j = T_{jmax}$ ; Gate open

# EVLYS LTD. - POWER SEMICONDUCTORS DEVICES - Wholesale and Retail.

<b>TRIGGERING</b>				
$I_{FGM}$	Peak forward gate current	A	6	$T_j = T_{j\max}$
$V_{RGM}$	Peak reverse gate voltage	V	5	
$P_G$	Gate power dissipation	W	3	$T_j = T_{j\max}$ for DC gate current
<b>SWITCHING</b>				
$(di_T/dt)_{crit}$	Critical rate of rise of on-state current non-repetitive (f=1 Hz)	A/ $\mu$ s	2000	$T_j = T_{j\max}$ ; $V_D = 0.67 \cdot V_{DRM}$ ; $I_{TM} = 900$ A; Gate pulse: $I_G = I_{FGM}$ ; $V_G = 20$ V; $t_{GP} = 50$ $\mu$ s; $di_G/dt = 2$ A/ $\mu$ s
<b>THERMAL</b>				
$T_{stg}$	Storage temperature	$^{\circ}$ C	-60...+50	
$T_j$	Operating junction temperature	$^{\circ}$ C	-60...+125	
<b>MECHANICAL</b>				
F	Mounting force	kN	9.0...11.0	
a	Acceleration	m/s <sup>2</sup>	50	Device clamped

## CHARACTERISTICS

Symbols and parameters		Units	Values	Conditions	
<b>ON-STATE</b>					
$V_{TM}$	Peak on-state voltage, max	V	3.30	$T_j = 25$ $^{\circ}$ C; $I_{TM} = 1256$ A	
$V_{T(TO)}$	On-state threshold voltage, max	V	1.775	$T_j = T_{j\max}$ ;	
$r_T$	On-state slope resistance, max	m $\Omega$	1.155	$0.5 \pi I_{TAV} < I_T < 1.5 \pi I_{TAV}$	
$I_H$	Holding current, max	mA	500	$T_j = 25$ $^{\circ}$ C; $V_D = 12$ V; Gate open	
<b>BLOCKING</b>					
$I_{DRM}, I_{RRM}$	Repetitive peak off-state and Repetitive peak reverse currents, max	mA	70	$T_j = T_{j\max}$ ; $V_D = V_{DRM}$ ; $V_R = V_{RRM}$	
$(dv_D/dt)_{crit}$	Critical rate of rise of off-state voltage <sup>1)</sup> , min	V/ $\mu$ s	200, 320, 500, 1000, 1600, 2000, 2500	$T_j = T_{j\max}$ ; $V_D = 0.67 \cdot V_{DRM}$ ; Gate open	
<b>TRIGGERING</b>					
$V_{GT}$	Gate trigger direct voltage, max	V	3.00 2.50 1.50	$T_j = T_{j\min}$ $T_j = 25$ $^{\circ}$ C $T_j = T_{j\max}$	$V_D = 12$ V; $I_D = 3$ A; Direct gate current
$I_{GT}$	Gate trigger direct current, max	mA	500 300 150	$T_j = T_{j\min}$ $T_j = 25$ $^{\circ}$ C $T_j = T_{j\max}$	
$V_{GD}$	Gate non-trigger direct voltage, min	V	0.40	$T_j = T_{j\max}$ ; $V_D = 0.67 \cdot V_{DRM}$ ;	
$I_{GD}$	Gate non-trigger direct current, min	mA	70.00	Direct gate current	
<b>SWITCHING</b>					
$t_{gd}$	Delay time, max	$\mu$ s	0.70	$T_j = 25$ $^{\circ}$ C; $V_D = 600$ V; $I_{TM} = I_{TAV}$ ; $di/dt = 200$ A/ $\mu$ s;	
$t_{gt}$	Turn-on time <sup>2)</sup> , max	$\mu$ s	1.25, 1.60, 2.00, 2.50	Gate pulse: $I_G = I_{FGM}$ ; $V_G = 20$ V; $t_{GP} = 50$ $\mu$ s; $di_G/dt = 2$ A/ $\mu$ s	
$t_q$	Turn-off time <sup>3)</sup> , max	$\mu$ s	5.00, 6.30, 8.00, 10.0	$dv_D/dt = 50$ V/ $\mu$ s;	
			6.30; 8.00, 10.00, 12.5	$dv_D/dt = 200$ V/ $\mu$ s;	
$Q_{rr}$	Total recovered charge, max	$\mu$ C	60	$T_j = T_{j\max}$ ; $I_{TM} = I_{TAV}$ ;	
$t_{rr}$	Reverse recovery time, typ	$\mu$ s	1.85	$di_R/dt = -50$ A/ $\mu$ s;	
$I_{rM}$	Peak reverse recovery current, max	A	65	$V_R = 100$ V	

# EVLYS LTD. - POWER SEMICONDUCTORS DEVICES - Wholesale and Retail.

<b>THERMAL</b>					
$R_{thjc}$	Thermal resistance, junction to case, max	°C/W	0.0400	Direct current	Double side cooled
$R_{thjc-A}$			0.0880		Anode side cooled
$R_{thjc-K}$			0.0720		Cathode side cooled
$R_{thck}$	Thermal resistance, case to heatsink, max	°C/W	0.0060	Direct current	
<b>MECHANICAL</b>					
w	Weight, max	g	92		
$D_s$	Surface creepage distance	mm (inch)	10.30 (0.405)		
$D_a$	Air strike distance	mm (inch)	6.30 (0.248)		

<b>PART NUMBERING GUIDE</b>							<b>NOTES</b>																																							
FIDT	32	400	12	7	1	4																																								
1	2	3	4	5	6	7																																								
1. FIDT — Fast Inverter Disc Thyristor with Distributed Amplified Gate 2. Element Diameter 3. Mean on-state current, A 4. Voltage code 5. Critical rate of rise of off-state voltage 6. Group of turn-off time ( $dv_D/dt=50\text{ V}/\mu\text{s}$ ) 7. Group of turn-on time							1) Critical rate of rise of off-state voltage <table border="1" style="width: 100%; border-collapse: collapse;"> <thead> <tr> <th style="text-align: left;">Symbol of Group</th> <th style="text-align: center;">4</th> <th style="text-align: center;">5</th> <th style="text-align: center;">6</th> <th style="text-align: center;">7</th> <th style="text-align: center;">8</th> <th style="text-align: center;">8,5</th> <th style="text-align: center;">9</th> </tr> </thead> <tbody> <tr> <td style="text-align: left;"><math>(dv_D/dt)_{crit}, \text{ V}/\mu\text{s}</math></td> <td style="text-align: center;">200</td> <td style="text-align: center;">320</td> <td style="text-align: center;">500</td> <td style="text-align: center;">1000</td> <td style="text-align: center;">1600</td> <td style="text-align: center;">2000</td> <td style="text-align: center;">2500</td> </tr> </tbody> </table> 2) Turn-on time <table border="1" style="width: 100%; border-collapse: collapse;"> <thead> <tr> <th style="text-align: left;">Symbol of group</th> <th style="text-align: center;">6</th> <th style="text-align: center;">5</th> <th style="text-align: center;">4</th> </tr> </thead> <tbody> <tr> <td style="text-align: left;"><math>t_{gt}, \mu\text{s}</math></td> <td style="text-align: center;">1.25</td> <td style="text-align: center;">1.60</td> <td style="text-align: center;">2.00</td> </tr> </tbody> </table> 3) Turn-off time ( $dv_D/dt=50\text{ V}/\mu\text{s}$ ) <table border="1" style="width: 100%; border-collapse: collapse;"> <thead> <tr> <th style="text-align: left;">Symbol of group</th> <th style="text-align: center;">1</th> <th style="text-align: center;">6.30</th> <th style="text-align: center;">8.00</th> <th style="text-align: center;">10.0</th> </tr> </thead> <tbody> <tr> <td style="text-align: left;"><math>t_q, \mu\text{s}</math></td> <td style="text-align: center;">5.00</td> <td style="text-align: center;">6.30</td> <td style="text-align: center;">8.00</td> <td style="text-align: center;">10.0</td> </tr> </tbody> </table>						Symbol of Group	4	5	6	7	8	8,5	9	$(dv_D/dt)_{crit}, \text{ V}/\mu\text{s}$	200	320	500	1000	1600	2000	2500	Symbol of group	6	5	4	$t_{gt}, \mu\text{s}$	1.25	1.60	2.00	Symbol of group	1	6.30	8.00	10.0	$t_q, \mu\text{s}$	5.00	6.30	8.00	10.0
Symbol of Group	4	5	6	7	8	8,5	9																																							
$(dv_D/dt)_{crit}, \text{ V}/\mu\text{s}$	200	320	500	1000	1600	2000	2500																																							
Symbol of group	6	5	4																																											
$t_{gt}, \mu\text{s}$	1.25	1.60	2.00																																											
Symbol of group	1	6.30	8.00	10.0																																										
$t_q, \mu\text{s}$	5.00	6.30	8.00	10.0																																										

# EVLYS LTD. - POWER SEMICONDUCTORS DEVICES - Wholesale and Retail.

## OVERALL DIMENSIONS

Package type: T.B2

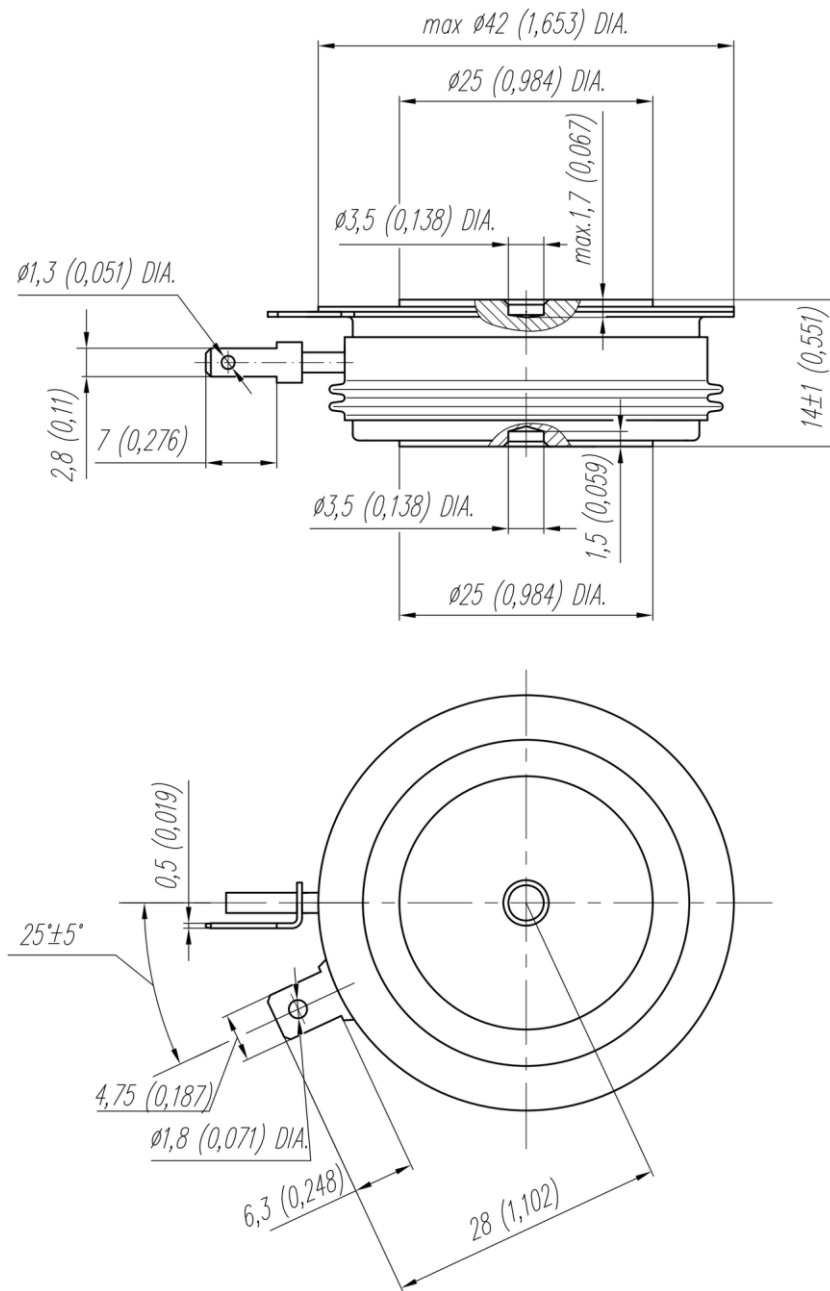

All dimensions in millimeters (inches)

# **EVLYS LTD. - POWER SEMICONDUCTORS DEVICES - Wholesale and Retail.**