

EVLYS LTD. - POWER SEMICONDUCTORS DEVICES - Wholesale and Retail.

Phase Control Disc Thyristor Type DT70-1000-52

High power cycling capability / Low on-state and switching losses
Designed for traction and industrial applications

Mean on-state current		I_{TAV}	1000 A	
Repetitive peak off-state voltage		V_{DRM}	4600 ÷ 5200 V	
Repetitive peak reverse voltage		V_{RRM}		
Turn-off time		t_q	800 μ s	
V_{DRM}, V_{RRM}, V	4600	4800	5000	5200
Voltage code	46	48	50	52
$T_j, ^\circ C$	- 60 ÷ 125			

MAXIMUM ALLOWABLE RATINGS

Symbols and parameters		Units	Values	Test conditions
ON-STATE				
I_{TAV}	Mean on-state current	A	1000 1476 1783	$T_c = 104^\circ C$, Double side cooled $T_c = 85^\circ C$, Double side cooled $T_c = 70^\circ C$, Double side cooled 180° half-sine wave; 50 Hz
I_{TRMS}	RMS on-state current	A	1570	$T_c = 104^\circ C$, Double side cooled 180° half-sine wave; 50 Hz
I_{TSM}	Surge on-state current	kA	26.0 30.0	$T_j = T_{jmax}$ $T_j = 25^\circ C$ 180° half-sine wave; 50 Hz ($t_p = 10$ ms); single pulse; $V_D = V_R = 0$ V; Gate pulse: $I_G = 2$ A; $t_{GP} = 50 \mu s$; $di_G/dt \geq 1$ A/ μs
			28.0 32.0	$T_j = T_{jmax}$ $T_j = 25^\circ C$ 180° half-sine wave; 60 Hz ($t_p = 8.3$ ms); single pulse; $V_D = V_R = 0$ V; Gate pulse: $I_G = 2$ A; $t_{GP} = 50 \mu s$; $di_G/dt \geq 1$ A/ μs
I^2t	Safety factor	$A^2s \cdot 10^3$	3380 4500	$T_j = T_{jmax}$ $T_j = 25^\circ C$ 180° half-sine wave; 50 Hz ($t_p = 10$ ms); single pulse; $V_D = V_R = 0$ V; Gate pulse: $I_G = 2$ A; $t_{GP} = 50 \mu s$; $di_G/dt \geq 1$ A/ μs
			3250 4245	$T_j = T_{jmax}$ $T_j = 25^\circ C$ 180° half-sine wave; 60 Hz ($t_p = 8.3$ ms); single pulse; $V_D = V_R = 0$ V; Gate pulse: $I_G = 2$ A; $t_{GP} = 50 \mu s$; $di_G/dt \geq 1$ A/ μs
BLOCKING				
V_{DRM}, V_{RRM}	Repetitive peak off-state and Repetitive peak reverse voltages	V	4600÷5200	$T_{jmin} < T_j < T_{jmax}$; 180° half-sine wave; 50 Hz; Gate open
V_{DSM}, V_{RSM}	Non-repetitive peak off-state and Non-repetitive peak reverse voltages	V	4700÷5300	$T_{jmin} < T_j < T_{jmax}$; 180° half-sine wave; 50 Hz; single pulse; Gate open
V_D, V_R	Direct off-state and Direct reverse voltages	V	0.75· V_{DRM} 0.75· V_{RRM}	$T_j = T_{jmax}$; Gate open

EVLYS LTD. - POWER SEMICONDUCTORS DEVICES - Wholesale and Retail.

TRIGGERING				
I_{FGM}	Peak forward gate current	A	8	$T_j = T_{j\ max}$
V_{RGM}	Peak reverse gate voltage	V	5	
P_G	Gate power dissipation	W	5	$T_j = T_{j\ max}$ for DC gate current
SWITCHING				
$(di_T/dt)_{crit}$	Critical rate of rise of on-state current non-repetitive (f=1 Hz)	A/ μ s	630	$T_j = T_{j\ max}$; $V_D = 0.67 \cdot V_{DRM}$; $I_{TM} = 2 I_{TAV}$; Gate pulse: $I_G = 2$ A; $t_{GP} = 50$ μ s; $di_G/dt \geq 1$ A/ μ s
THERMAL				
T_{stg}	Storage temperature	$^{\circ}$ C	-60 ÷ 125	
T_j	Operating junction temperature	$^{\circ}$ C	-60 ÷ 125	
MECHANICAL				
F	Mounting force	kN	33.0 ÷ 40.0	
a	Acceleration	m/s^2	50 100	Device unclamped Device clamped

CHARACTERISTICS

Symbols and parameters		Units	Values	Conditions	
ON-STATE					
V_{TM}	Peak on-state voltage, max	V	2.80	$T_j = 25$ $^{\circ}$ C; $I_{TM} = 5000$ A	
$V_{T(TO)}$	On-state threshold voltage, max	V	0.90	$T_j = T_{j\ max}$;	
r_T	On-state slope resistance, max	m Ω	0.500	$0.5 \pi I_{TAV} < I_T < 1.5 \pi I_{TAV}$	
I_L	Latching current, max	mA	1500	$T_j = 25$ $^{\circ}$ C; $V_D = 12$ V; Gate pulse: $I_G = 2$ A; $t_{GP} = 50$ μ s; $di_G/dt \geq 1$ A/ μ s	
I_H	Holding current, max	mA	300	$T_j = 25$ $^{\circ}$ C; $V_D = 12$ V; Gate open	
BLOCKING					
I_{DRM}, I_{RRM}	Repetitive peak off-state and Repetitive peak reverse currents, max	mA	200	$T_j = T_{j\ max}$; $V_D = V_{DRM}$; $V_R = V_{RRM}$	
$(dv_D/dt)_{crit}$	Critical rate of rise of off-state voltage ¹⁾ , min	V/ μ s	1000	$T_j = T_{j\ max}$; $V_D = 0.67 \cdot V_{DRM}$; Gate open	
TRIGGERING					
V_{GT}	Gate trigger direct voltage, max	V	5.00	$T_j = T_{j\ min}$ $T_j = 25$ $^{\circ}$ C $T_j = T_{j\ max}$	$V_D = 12$ V; $I_D = 3$ A; Direct gate current
			3.00		
			2.00		
I_{GT}	Gate trigger direct current, max	mA	500	$T_j = T_{j\ min}$ $T_j = 25$ $^{\circ}$ C $T_j = T_{j\ max}$	
			300		
			200		
V_{GD}	Gate non-trigger direct voltage, min	V	0.35	$T_j = T_{j\ max}$; $V_D = 0.67 \cdot V_{DRM}$;	
I_{GD}	Gate non-trigger direct current, min	mA	15.00	Direct gate current	
SWITCHING					
t_{gd}	Delay time	μ s	4.00	$T_j = 25$ $^{\circ}$ C; $V_D = 0.4 \cdot V_{DRM}$; $I_{TM} = I_{TAV}$; Gate pulse: $I_G = 2$ A; $t_{GP} = 50$ μ s; $di_G/dt \geq 1$ A/ μ s	
t_q	Turn-off time ²⁾ , max	μ s	800	$dv_D/dt = 50$ V/ μ s; $T_j = T_{j\ max}$; $I_{TM} = 2000$ A; $di_R/dt = -10$ A/ μ s; $V_R = 100$ V; $V_D = 0.67 V_{DRM}$;	

EVLYS LTD. - POWER SEMICONDUCTORS DEVICES - Wholesale and Retail.

THERMAL					
R_{thjc}	Thermal resistance, junction to case, max	°C/W	0.0100	Direct current	Double side cooled
R_{thjc-A}			0.0220		Anode side cooled
R_{thjc-K}			0.0180		Cathode side cooled
R_{thck}	Thermal resistance, case to heatsink, max	°C/W	0.0030	Direct current	
MECHANICAL					
w	Weight, typ	g	1000		
D_s	Surface creepage distance	mm (inch)	36.50 (1.437)		
D_a	Air strike distance	mm (inch)	16.5 (0.650)		

PART NUMBERING GUIDE				
DT	70	1000	52	
1	2	3	4	
1. DT - Phase Control Disc Thyristor 2. Element Diameter 3. Mean on-state current, A 4. Voltage code				

EVLYS LTD. - POWER SEMICONDUCTORS DEVICES - Wholesale and Retail.

OVERALL DIMENSIONS

Package type: T.E3

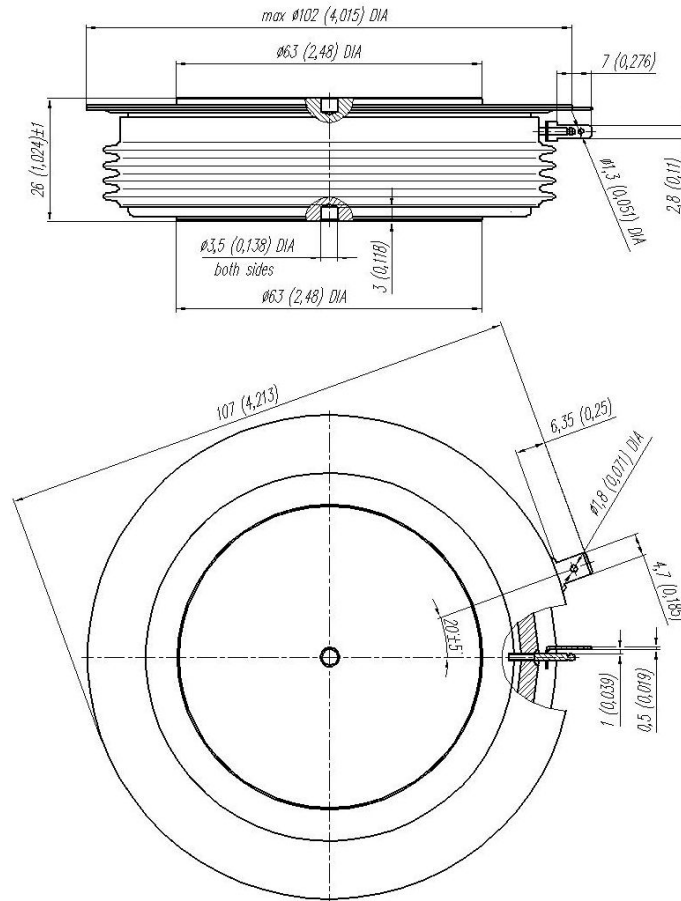

All dimensions in millimeters (inches)