

EVLYS LTD. - POWER SEMICONDUCTORS DEVICES - Wholesale and Retail.

Phase Control Disc Thyristor Type DT56-800-36

High power cycling capability / Low on-state and switching losses
Designed for traction and industrial applications

Mean on-state current	I_{TAV}		800 A		
Repetitive peak off-state voltage	V_{DRM}		2800 ÷ 3600 V		
Repetitive peak reverse voltage	V_{RRM}				
Turn-off time	t_q		320, 400, 500 μ s		
V_{DRM}, V_{RRM}, V	2800	3000	3200	3400	3600
Voltage code	28	30	32	34	36
$T_j, ^\circ C$	-60...+125				

MAXIMUM ALLOWABLE RATINGS

Symbols and parameters		Units	Values	Test conditions	
ON-STATE					
I_{TAV}	Maximum allowable mean on-state current	A	800 973	$T_c=94^\circ C$, Double side cooled $T_c=85^\circ C$, Double side cooled 180° half-sine wave; 50 Hz	
I_{TRMS}	RMS on-state current	A	1256	$T_c=94^\circ C$, Double side cooled 180° half-sine wave; 50 Hz	
I_{TSM}	Surge on-state current	kA	18.0 21.0	$T_j=T_{jmax}$ $T_j=25^\circ C$	180° half-sine wave; $t_p=10$ ms; single pulse; $V_D=V_R=0$ V; Gate pulse: $I_G=2$ A; $t_{GP}=50$ μ s; $di_G/dt \geq 1$ A/ μ s
			19.0 22.0	$T_j=T_{jmax}$ $T_j=25^\circ C$	180° half-sine wave; $t_p=8.3$ ms; single pulse; $V_D=V_R=0$ V; Gate pulse: $I_G=2$ A; $t_{GP}=50$ μ s; $di_G/dt \geq 1$ A/ μ s
I^2t	Safety factor	$A^2s \cdot 10^3$	1600 2200	$T_j=T_{jmax}$ $T_j=25^\circ C$	180° half-sine wave; $t_p=10$ ms; single pulse; $V_D=V_R=0$ V; Gate pulse: $I_G=2$ A; $t_{GP}=50$ μ s; $di_G/dt \geq 1$ A/ μ s
			1400 2000	$T_j=T_{jmax}$ $T_j=25^\circ C$	180° half-sine wave; $t_p=8.3$ ms; single pulse; $V_D=V_R=0$ V; Gate pulse: $I_G=2$ A; $t_{GP}=50$ μ s; $di_G/dt \geq 1$ A/ μ s
BLOCKING					
V_{DRM}, V_{RRM}	Repetitive peak off-state and Repetitive peak reverse voltages	V	2800...3600	$T_{jmin} < T_j < T_{jmax}$; 180° half-sine wave; 50 Hz; Gate open	
V_{DSM}, V_{RSM}	Non-repetitive peak off-state and Non-repetitive peak reverse voltages	V	2900...3700	$T_{jmin} < T_j < T_{jmax}$; 180° half-sine wave; single pulse; Gate open	
V_D, V_R	Direct off-state and Direct reverse voltages	V	$0.6 \cdot V_{DRM}$ $0.6 \cdot V_{RRM}$	$T_j=T_{jmax}$; Gate open	

EVLYS LTD. - POWER SEMICONDUCTORS DEVICES - Wholesale and Retail.

TRIGGERING				
I_{FGM}	Peak forward gate current	A	8	$T_j = T_{j\max}$
V_{RGM}	Peak reverse gate voltage	V	5	
P_G	Gate power dissipation	W	4	$T_j = T_{j\max}$ for DC gate current
SWITCHING				
$(di_T/dt)_{crit}$	Critical rate of rise of on-state current non-repetitive (f=1 Hz)	A/ μ s	1250	$T_j = T_{j\max}$; $V_D = 0.67 \cdot V_{DRM}$; $I_{TM} = 1800$ A; Gate pulse: $I_G = 2$ A; $t_{GP} = 50$ μ s; $di_G/dt \geq 2$ A/ μ s
THERMAL				
T_{stg}	Storage temperature	$^{\circ}$ C	-60...+50	
T_j	Operating junction temperature	$^{\circ}$ C	-60...+125	
MECHANICAL				
F	Mounting force	kN	24.0...28.0	
a	Acceleration	m/s ²	50	Device clamped

CHARACTERISTICS

Symbols and parameters		Units	Values	Conditions	
ON-STATE					
V_{TM}	Peak on-state voltage, max	V	2.00	$T_j = 25$ $^{\circ}$ C; $I_{TM} = 2512$ A	
$V_{T(TO)}$	On-state threshold voltage, max	V	1.18	$T_j = T_{j\max}$;	
r_T	On-state slope resistance, max	m Ω	0.462	$0.5 \pi I_{TAV} < I_T < 1.5 \pi I_{TAV}$	
I_L	Latching current, max	mA	1500	$T_j = 25$ $^{\circ}$ C; $V_D = 12$ V; Gate pulse: $I_G = 2$ A; $t_{GP} = 50$ μ s; $di_G/dt \geq 1$ A/ μ s	
I_H	Holding current, max	mA	300	$T_j = 25$ $^{\circ}$ C; $V_D = 12$ V; Gate open	
BLOCKING					
I_{DRM} , I_{RRM}	Repetitive peak off-state and Repetitive peak reverse currents, max	mA	150	$T_j = T_{j\max}$; $V_D = V_{DRM}$; $V_R = V_{RRM}$	
$(dv_D/dt)_{crit}$	Critical rate of rise of off-state voltage ¹⁾ , min	V/ μ s	200, 320, 500, 1000, 1600, 2000, 2500	$T_j = T_{j\max}$; $V_D = 0.67 \cdot V_{DRM}$; Gate open	
TRIGGERING					
V_{GT}	Gate trigger direct voltage, max	V	3.00 2.50 1.50	$T_j = T_{j\min}$ $T_j = 25$ $^{\circ}$ C $T_j = T_{j\max}$	$V_D = 12$ V; $I_D = 3$ A; Direct gate current
I_{GT}	Gate trigger direct current, max	mA	500 300 150	$T_j = T_{j\min}$ $T_j = 25$ $^{\circ}$ C $T_j = T_{j\max}$	
V_{GD}	Gate non-trigger direct voltage, min	V	0.50	$T_j = T_{j\max}$;	
I_{GD}	Gate non-trigger direct current, min	mA	90.00	$V_D = 0.67 \cdot V_{DRM}$; Direct gate current	
SWITCHING					
t_{gd}	Delay time	μ s	2.05	$T_j = 25$ $^{\circ}$ C; $V_D = 1500$ V; $I_{TM} = I_{TAV}$; $di/dt = 200$ A/ μ s;	
t_{gt}	Turn-on time, max	μ s	8.00	Gate pulse: $I_G = 2$ A; $V_G = 20$ V; $t_{GP} = 50$ μ s; $di_G/dt = 2$ A/ μ s	
t_q	Turn-off time ²⁾ , max	μ s	320, 400, 500	$dv_D/dt = 50$ V/ μ s; $T_j = T_{j\max}$; $I_{TM} = I_{TAV}$; $di_R/dt = -5$ A/ μ s; $V_R = 100$ V; $V_D = 0.67 \cdot V_{DRM}$	
Q_{rr}	Recovered charge, max	μ C	3500	$T_j = T_{j\max}$; $I_{TM} = I_{TAV}$;	
t_{rr}	Reverse recovery time, max	μ s	56	$di_R/dt = -5$ A/ μ s;	
I_{rr}	Reverse recovery current, max	A	125	$V_R = 100$ V;	

EVLYS LTD. - POWER SEMICONDUCTORS DEVICES - Wholesale and Retail.

THERMAL					
R_{thjc}	Thermal resistance, junction to case, max	°C/W	0.0180	Direct current	Double side cooled
R_{thjc-A}			0.0396		Anode side cooled
R_{thjc-K}			0.0324		Cathode side cooled
R_{thck}	Thermal resistance, case to heatsink, max	°C/W	0.0040	Direct current	
MECHANICAL					
m	Weight, max	g	510		
D_s	Surface creepage distance	mm (inch)	31.60 (1.244)		
D_a	Air strike distance	mm (inch)	16.50 (0.649)		

PART NUMBERING GUIDE							NOTES																							
DT	56	800	36	7	3		1) Critical rate of rise of off-state voltage <table border="1" style="width: 100%; border-collapse: collapse;"> <thead> <tr> <th style="text-align: left;">Symbol of Group</th> <th style="text-align: center;">4</th> <th style="text-align: center;">5</th> <th style="text-align: center;">6</th> <th style="text-align: center;">7</th> <th style="text-align: center;">8</th> <th style="text-align: center;">8.5</th> <th style="text-align: center;">9</th> </tr> </thead> <tbody> <tr> <td style="text-align: left;">$(dv_d/dt)_{crit}, V/\mu s$</td> <td style="text-align: center;">200</td> <td style="text-align: center;">320</td> <td style="text-align: center;">500</td> <td style="text-align: center;">1000</td> <td style="text-align: center;">1600</td> <td style="text-align: center;">2000</td> <td style="text-align: center;">2500</td> </tr> </tbody> </table>								Symbol of Group	4	5	6	7	8	8.5	9	$(dv_d/dt)_{crit}, V/\mu s$	200	320	500	1000	1600	2000	2500
Symbol of Group	4	5	6	7	8	8.5									9															
$(dv_d/dt)_{crit}, V/\mu s$	200	320	500	1000	1600	2000	2500																							
1	2	3	4	5	6																									
1. DT - Phase Control Disc Thyristor 2. Element Diameter 3. Mean on-state current, A 4. Voltage code 5. Critical rate of rise of on-state current non-repetitive, V/ μs 6. Turn-off time ($dv_d/dt=50 V/\mu s$)							2) Turn-off time ($dv_d/dt=50 V/\mu s$) <table border="1" style="width: 100%; border-collapse: collapse;"> <thead> <tr> <th style="text-align: left;">Symbol of Group</th> <th style="text-align: center;">0</th> <th style="text-align: center;">0</th> <th style="text-align: center;">0</th> </tr> </thead> <tbody> <tr> <td style="text-align: left;">$t_a, \mu s$</td> <td style="text-align: center;">320</td> <td style="text-align: center;">400</td> <td style="text-align: center;">500</td> </tr> </tbody> </table>								Symbol of Group	0	0	0	$t_a, \mu s$	320	400	500								
Symbol of Group	0	0	0																											
$t_a, \mu s$	320	400	500																											

EVLYS LTD. - POWER SEMICONDUCTORS DEVICES - Wholesale and Retail.

OVERALL DIMENSIONS

Package type: T.D5

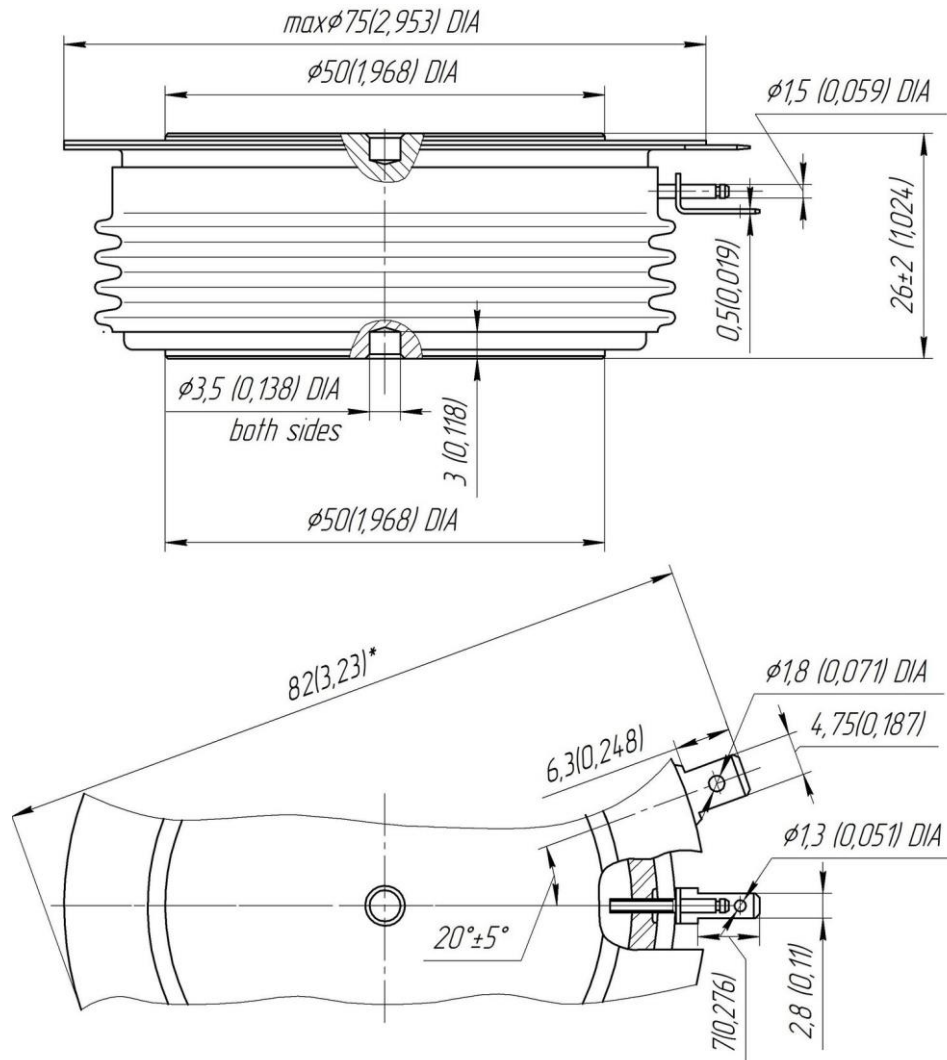

All dimensions in millimeters (inches)