

Phase Control Disc Thyristor Type DT40-400-44

High power cycling capability / Low on-state and switching losses
Designed for traction and industrial applications

Mean on-state current	I_{TAV}		400 A	
Repetitive peak off-state voltage	V_{DRM}		3800 ÷ 4400 V	
Repetitive peak reverse voltage	V_{RRM}			
Turn-off time	t_q		500, 630, 800 μ s	
V_{DRM}, V_{RRM}, V	3800	4000	4200	4400
Voltage code	38	40	42	44
$T_j, ^\circ C$	-60 ÷ 125			

MAXIMUM ALLOWABLE RATINGS

Symbols and parameters		Units	Values	Test conditions
ON-STATE				
I_{TAV}	Mean on-state current	A	400 455	$T_c=92^\circ C$, Double side cooled $T_c=85^\circ C$, Double side cooled 180° half-sine wave; 50 Hz
I_{TRMS}	RMS on-state current	A	628	$T_c=92^\circ C$, Double side cooled 180° half-sine wave; 50 Hz
I_{TSM}	Surge on-state current	kA	6.5 7.5	$T_j=T_{jmax}$ $T_j=25^\circ C$ 180° half-sine wave; $t_p=10$ ms; single pulse; $V_D=V_R=0$ V; Gate pulse: $I_G=2$ A; $t_{GP}=50$ μ s; $di_G/dt \geq 1$ A/ μ s
			7.0 8.0	$T_j=T_{jmax}$ $T_j=25^\circ C$ 180° half-sine wave; $t_p=8.3$ ms; single pulse; $V_D=V_R=0$ V; Gate pulse: $I_G=2$ A; $t_{GP}=50$ μ s; $di_G/dt \geq 1$ A/ μ s
I^2t	Safety factor	$A^2s \cdot 10^3$	210 280	$T_j=T_{jmax}$ $T_j=25^\circ C$ 180° half-sine wave; $t_p=10$ ms; single pulse; $V_D=V_R=0$ V; Gate pulse: $I_G=2$ A; $t_{GP}=50$ μ s; $di_G/dt \geq 1$ A/ μ s
			200 260	$T_j=T_{jmax}$ $T_j=25^\circ C$ 180° half-sine wave; $t_p=8.3$ ms; single pulse; $V_D=V_R=0$ V; Gate pulse: $I_G=2$ A; $t_{GP}=50$ μ s; $di_G/dt \geq 1$ A/ μ s
BLOCKING				
V_{DRM}, V_{RRM}	Repetitive peak off-state and Repetitive peak reverse voltages	V	3800 ÷ 4400	$T_{jmin} < T_j < T_{jmax}$; 180° half-sine wave; 50 Hz; Gate open
V_{DSM}, V_{RSM}	Non-repetitive peak off-state and Non-repetitive peak reverse voltages	V	3900 ÷ 4500	$T_{jmin} < T_j < T_{jmax}$; 180° half-sine wave; single pulse; Gate open
V_D, V_R	Direct off-state and Direct reverse voltages	V	$0.6 \cdot V_{DRM}$ $0.6 \cdot V_{RRM}$	$T_j = T_{jmax}$; Gate open

TRIGGERING				
I_{FGM}	Peak forward gate current	A	8	$T_j = T_{j\max}$
V_{RGM}	Peak reverse gate voltage	V	5	
P_G	Gate power dissipation	W	4	$T_j = T_{j\max}$ for DC gate current
SWITCHING				
$(di_T/dt)_{crit}$	Critical rate of rise of on-state current non-repetitive ($f=1$ Hz)	A/ μ S	500	$T_j = T_{j\max}$; $V_D = 0.67 \cdot V_{DRM}$; $I_{TM} = 1250$ A; Gate pulse: $I_G = 2$ A; $t_{GP} = 50$ μ S; $di_G/dt \geq 2$ A/ μ S
THERMAL				
T_{stg}	Storage temperature	$^{\circ}$ C	-60÷50	
T_j	Operating junction temperature	$^{\circ}$ C	-60÷125	
MECHANICAL				
F	Mounting force	kN	14.0÷16.0	
a	Acceleration	m/s ²	50	Device clamped

CHARACTERISTICS

Symbols and parameters		Units	Values	Conditions	
ON-STATE					
V_{TM}	Peak on-state voltage, max	V	2.25	$T_j = 25$ $^{\circ}$ C; $I_{TM} = 1256$ A	
$V_{T(TO)}$	On-state threshold voltage, max	V	1.117	$T_j = T_{j\max}$;	
r_T	On-state slope resistance, max	m Ω	1.245	$0.5 \pi I_{TAV} < I_T < 1.5 \pi I_{TAV}$	
I_L	Latching current, max	mA	1000	$T_j = 25$ $^{\circ}$ C; $V_D = 12$ V; Gate pulse: $I_G = 2$ A; $t_{GP} = 50$ μ S; $di_G/dt \geq 1$ A/ μ S	
I_H	Holding current, max	mA	300	$T_j = 25$ $^{\circ}$ C; $V_D = 12$ V; Gate open	
BLOCKING					
I_{DRM}, I_{RRM}	Repetitive peak off-state and Repetitive peak reverse currents, max	mA	100	$T_j = T_{j\max}$; $V_D = V_{DRM}$; $V_R = V_{RRM}$	
$(dv_D/dt)_{crit}$	Critical rate of rise of off-state voltage ¹⁾ , min	V/ μ S	200, 320, 500, 1000, 1600, 2000, 2500	$T_j = T_{j\max}$; $V_D = 0.67 \cdot V_{DRM}$; Gate open	
TRIGGERING					
V_{GT}	Gate trigger direct voltage, max	V	3.00 2.50 1.50	$T_j = T_{j\min}$ $T_j = 25$ $^{\circ}$ C $T_j = T_{j\max}$	$V_D = 12$ V; $I_D = 3$ A; Direct gate current
I_{GT}	Gate trigger direct current, max	mA	400 250 150	$T_j = T_{j\min}$ $T_j = 25$ $^{\circ}$ C $T_j = T_{j\max}$	
V_{GD}	Gate non-trigger direct voltage, min	V	0.45	$T_j = T_{j\max}$;	
I_{GD}	Gate non-trigger direct current, min	mA	55.00	$V_D = 0.67 \cdot V_{DRM}$; Direct gate current	
SWITCHING					
t_{gd}	Delay time, max	μ S	3.20	$T_j = 25$ $^{\circ}$ C; $V_D = 1500$ V; $I_{TM} = I_{TAV}$; $di/dt = 200$ A/ μ S;	
t_{gt}	Turn-on time, max	μ S	15.00	Gate pulse: $I_G = 2$ A; $V_G = 20$ V; $t_{GP} = 50$ μ S; $di_G/dt = 2$ A/ μ S	
t_q	Turn-off time ²⁾ , max	μ S	500, 630, 800	$dv_D/dt = 50$ V/ μ S; $T_j = T_{j\max}$; $I_{TM} = I_{TAV}$; $di_R/dt = -10$ A/ μ S; $V_R = 100$ V; $V_D = 0.67 \cdot V_{DRM}$	
Q_{rr}	Total recovered charge, max	μ C	1760	$T_j = T_{j\max}$; $I_{TM} = 400$ A;	
t_{rr}	Reverse recovery time, max	μ S	40	$di_R/dt = -5$ A/ μ S;	
I_{rrM}	Peak reverse recovery current, max	A	88	$V_R = 100$ V	

THERMAL					
R_{thjc}	Thermal resistance, junction to case, max	°C/W	0.0350	Direct current	Double side cooled
R_{thjc-A}			0.0770		Anode side cooled
R_{thjc-K}			0.0630		Cathode side cooled
R_{thck}	Thermal resistance, case to heatsink, max	°C/W	0.0060	Direct current	
MECHANICAL					
w	Weight, max	g	280		
D_s	Surface creepage distance	mm (inch)	27.60 (1.087)		
D_a	Air strike distance	mm (inch)	16.00 (0.630)		

PART NUMBERING GUIDE							NOTES																						
DT	40	400	44	7	2		1) Critical rate of rise of off-state voltage																						
1	2	3	4	5	6		<table border="1"> <thead> <tr> <th>Symbol of Group</th> <th>4</th> <th>5</th> <th>6</th> <th>7</th> <th>8</th> <th>8.5</th> <th>9</th> </tr> </thead> <tbody> <tr> <td>$(dv_D/dt)_{crit}, V/\mu s$</td> <td>200</td> <td>320</td> <td>500</td> <td>1000</td> <td>1600</td> <td>2000</td> <td>2500</td> </tr> </tbody> </table>							Symbol of Group	4	5	6	7	8	8.5	9	$(dv_D/dt)_{crit}, V/\mu s$	200	320	500	1000	1600	2000	2500
Symbol of Group	4	5	6	7	8	8.5	9																						
$(dv_D/dt)_{crit}, V/\mu s$	200	320	500	1000	1600	2000	2500																						
1. DT - Phase Control Disc Thyristor 2. Element Diameter 3. Mean on-state current, A 4. Voltage code 5. Critical rate of rise of on-state current non-repetitive, V/ μs 6. Turn-off time ($dv_D/dt=50 V/\mu s$)							2) Turn-off time ($dv_D/dt=50 V/\mu s$) <table border="1"> <thead> <tr> <th>Symbol of Group</th> <th>0</th> <th>0</th> <th>0</th> </tr> </thead> <tbody> <tr> <td>$t_d, \mu s$</td> <td>500</td> <td>630</td> <td>800</td> </tr> </tbody> </table>							Symbol of Group	0	0	0	$t_d, \mu s$	500	630	800								
Symbol of Group	0	0	0																										
$t_d, \mu s$	500	630	800																										

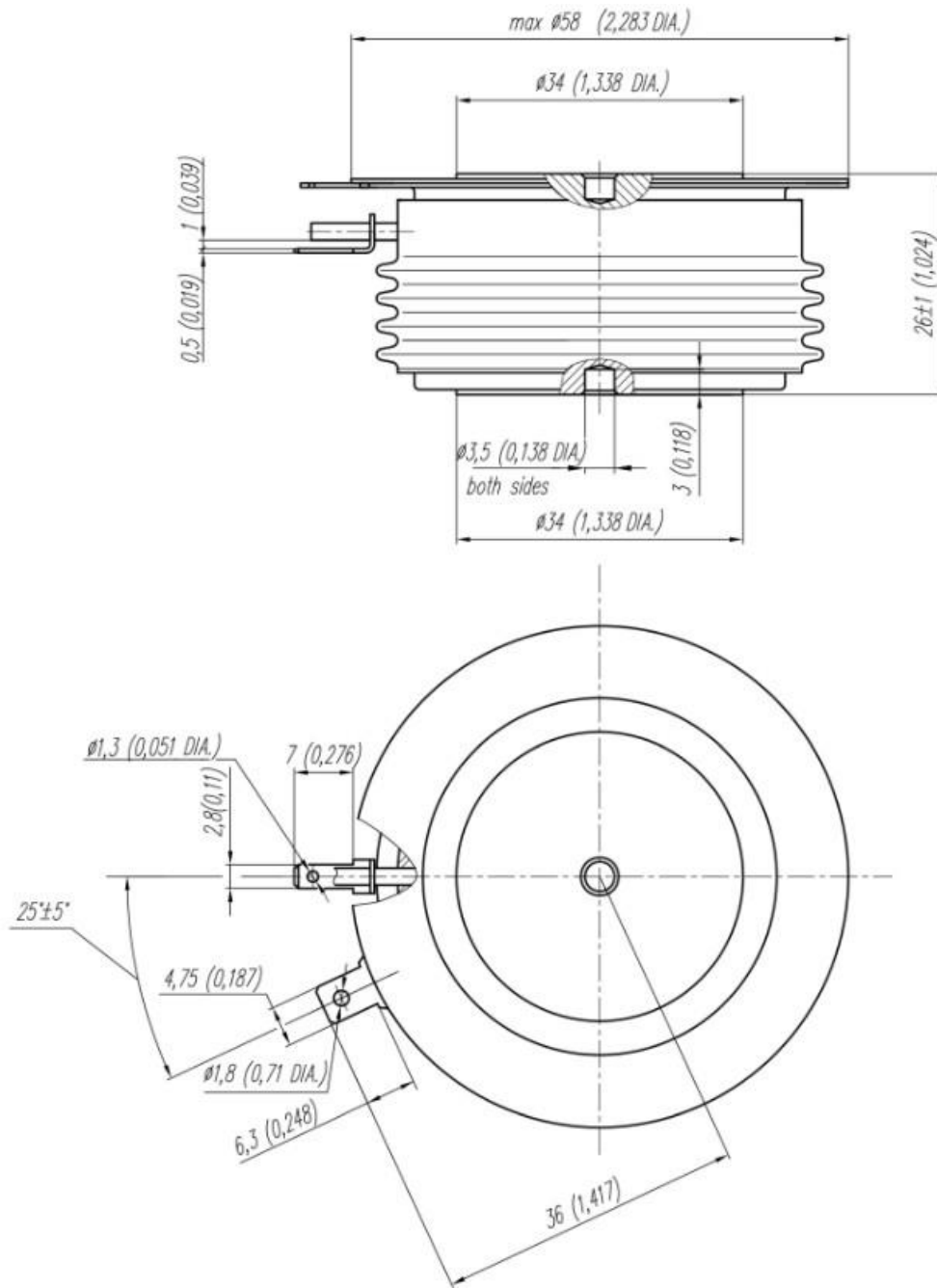

All dimensions in millimeters (inches)